

# E-BUS Distribution Module Technical Guide

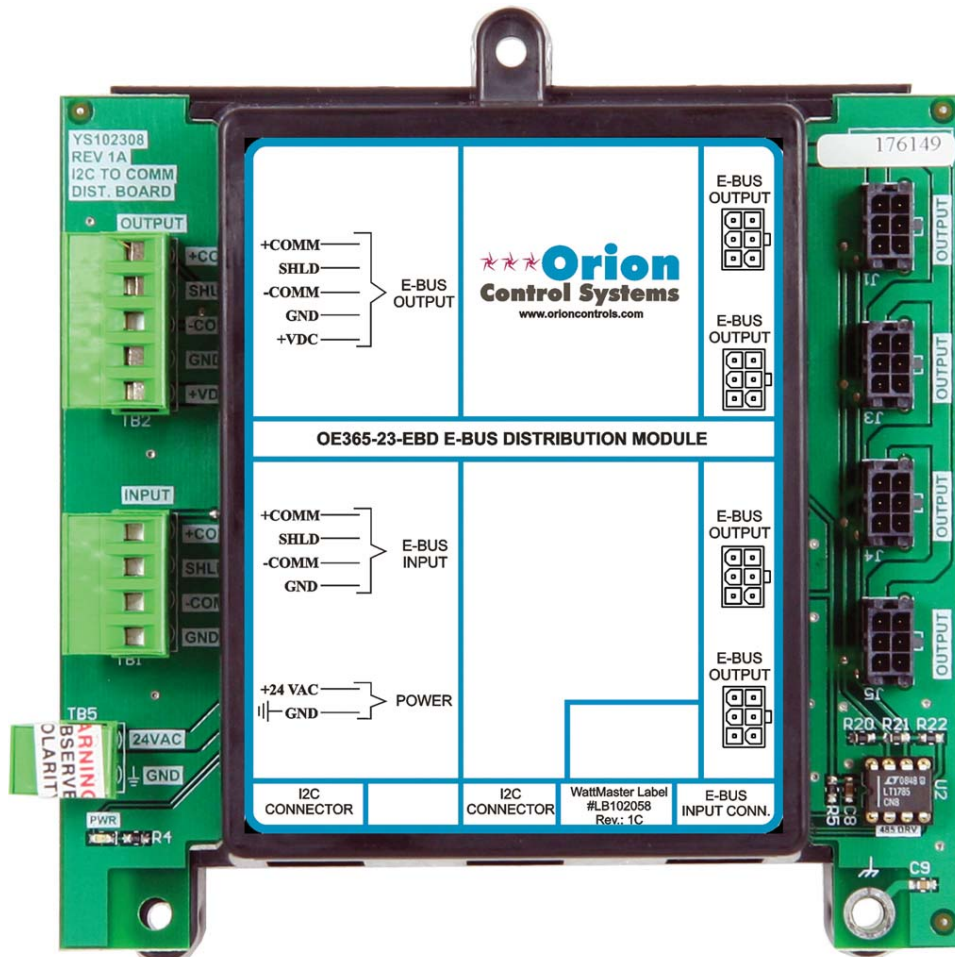

# Table of Contents

OVERVIEW.....	3
INSTALLATION AND WIRING .....	4
Environmental Requirements.....	4
Mounting.....	4
Power Supply .....	4
Important Wiring Considerations.....	5
E-BUS Modular Connection Wiring.....	6
E-BUS Terminal Block Wiring.....	7
EBTRON® Air Flow Measurement Digital Transmitter .....	8
TROUBLESHOOTING.....	9
Using LEDs to Verify Operation.....	9
LED Diagnostics.....	10
Other Checks .....	10

PART NUMBER CROSS REFERENCE TABLE	
PART DESCRIPTION	ORION PART NO.
E-BUS Distribution Module	OE365-23-EBD
SA Controller	OE332-23-SA-A
SA Expansion Module	OE333-23-SA-A
VCM-X Controller	OE332-23-VCMX
VCM-X Modular Controller (Tulsa)	OE332-23-VCMX-MOD-A
VCM-X Modular Controller (Coil)	OE332-23-VCMX-MOD-C
VCM-X WSHP Controller (Tulsa)	OE332-23-VCMX-WSHP-A
VCM-X WSHP Controller (Coil)	OE332-23-VCMX-WSHP-C
VCM-X Expansion Module	OE333-23-EM
VCM-X 12 Relay Expansion Module	OE358-23-12R
VCM-X One Condenser Head Pressure Module	OE370-23-HP1C
VCM-X Two Condenser Head Pressure Module	OE370-23-HP2C
VCM-X Full Digital Module (Tulsa)	OE370-23-FD-A
VCM-X Dual Digital Module (Coil)	OE370-23-DD-C
VCM-X WSHP Protection Module (Tulsa)	OE334-23-WPM-A
VCM-X WSHP Protection Module (Coil)	OE334-23-WPM-C
VCM-X WSHP Protection Module - R22 (Tulsa)	OE334-23-WPM-R22-A



www.orioncontrols.com

WattMaster Controls Inc.  
 8500 NW River Park Drive · Parkville, MO 64152  
 Toll Free Phone: 866-918-1100  
 PH: (816) 505-1100 · FAX: (816) 505-1101 · E-mail: mail@wattmaster.com  
 Visit our web site at www.orioncontrols.com  
 Form: OR-EBD-TGD-01G Copyright 2010 WattMaster Controls, Inc.

AAON® is a registered trademark of AAON, Inc., Tulsa, OK.  
 EBTRON® is a registered trademark of Ebtron, Inc., Loris, SC.  
 WattMaster Controls, Inc. assumes no responsibility for errors or omissions.  
 This document is subject to change without notice.

Overview

The E-BUS Distribution Module (OE365-23-EBD) is a communications device that allows E-BUS Modules to be connected to controllers with I<sup>2</sup>C communications such as the VCM-X Controller, the SA Controller, and their standard expansion modules.

The E-BUS Distribution Module allows the following E-BUS Modules to be connected to the VCM-X Controller:

- Dual Digital Module (OE370-23-DD)
- Full Digital Module (OE370-23-FD)
- One Condenser Head Pressure Module (OE370-23-HP1C)
- Two Condenser Head Pressure Module (OE370-23-HP2C)
- Water Source Heat Pump Protection Module (OE334-23-WPM and OE-334-23-WPM-R22)

The E-BUS Distribution Module allows the following E-BUS Modules to be connected to the SA Controller:

- Two Condenser Head Pressure Module (OE370-23-HP2C)
- Water Source Heat Pump Protection Module (OE334-23-WPM-A)

The E-BUS Modules are connected to the E-BUS Distribution Module by HSSC Series Modular Cables that can be ordered in various lengths. See **Figure 3** for the HSSC cable length options.

All E-BUS Modules require a 24 VAC power connection with an appropriate VA rating. The E-BUS Distribution Module can provide limited power for E-BUS Communicating Sensors (limited to 400 mA total).

The E-BUS Distribution Module also provides terminal block connections for applications that require pulling multi-conductor wire through conduit for applications requiring longer wire runs.

NOTE: The E-BUS Distribution Module contains no user-serviceable parts. Contact qualified technical personnel if your module is not operating correctly.

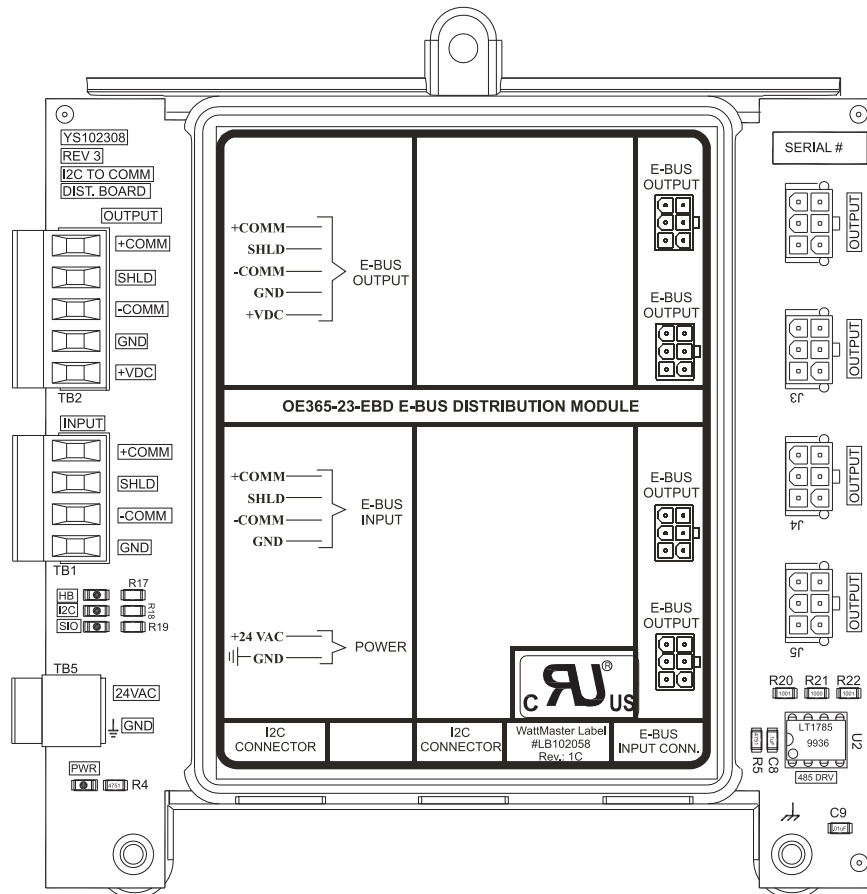

Figure 1: E-BUS Distribution Module

## Installation and Wiring

### Environmental Requirements

The E-BUS Distribution Module needs to be installed in an environment which can maintain a temperature range between -30°F and 150°F and not exceed 90% relative humidity levels (non-condensing).

### Mounting

The E-BUS Distribution Module is housed in a plastic enclosure. It is designed to be mounted by using the 3 mounting holes in the enclosure base. It is important to mount the module in a location that is free from extreme high or low temperatures, moisture, dust, and dirt. Be careful not to damage the electronic components when mounting the module.

See **Figure 2** for Module dimensions. All dimensions are in inches.

### Power Supply

The E-BUS Distribution Module requires a 24 VAC power connection with an appropriate VA rating.

**WARNING:** Observe polarity! All boards must be wired GND-to-GND and 24 VAC-to-VAC. Failure to observe polarity could result in damage to the boards.

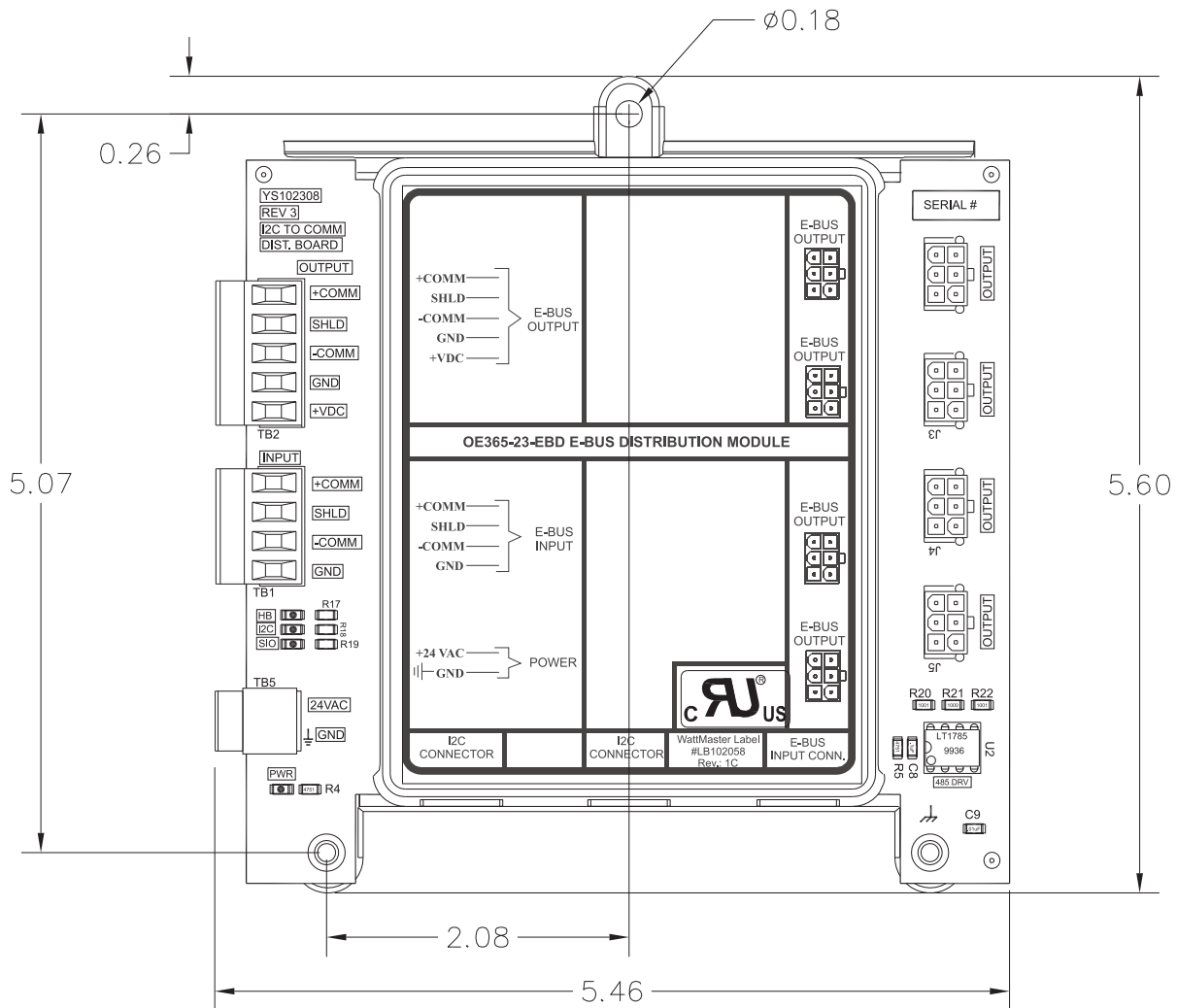

**Note:** Height is 1.49 inches.

**Figure 2: E-BUS Distribution Module Dimensions**

### Important Wiring Considerations

Please carefully read and apply the following information when wiring the E-BUS Distribution Module:

1. All 24 VAC wiring must be connected so that all ground wires remain common. Failure to follow this procedure can result in damage to the controller and connected devices.
2. All wiring is to be in accordance with local and national electrical codes and specifications.
3. Minimum wire size for 24 VAC wiring should be 18 gauge.
4. Be sure that all wiring connections are properly inserted and tightened into the terminal blocks. Do not allow wire strands to stick out and touch adjoining terminals which could potentially cause a short circuit.

5. Be sure all modular wiring harness connectors are seated firmly in their respective modular connectors on the circuit board.

NOTE: Contact Factory for the correct HSSC cable length for your application. Cables are available in 1/4, 1/2, 1, 2, 3, 4, and 5 Meter lengths and 100 and 150 Foot lengths.

NOTE: For Terminal Block Connection, see **Figure 5**.

WARNING: The E-BUS Distribution Module must be powered down before connecting the HSSC cable to a VCM-X or SA Module.

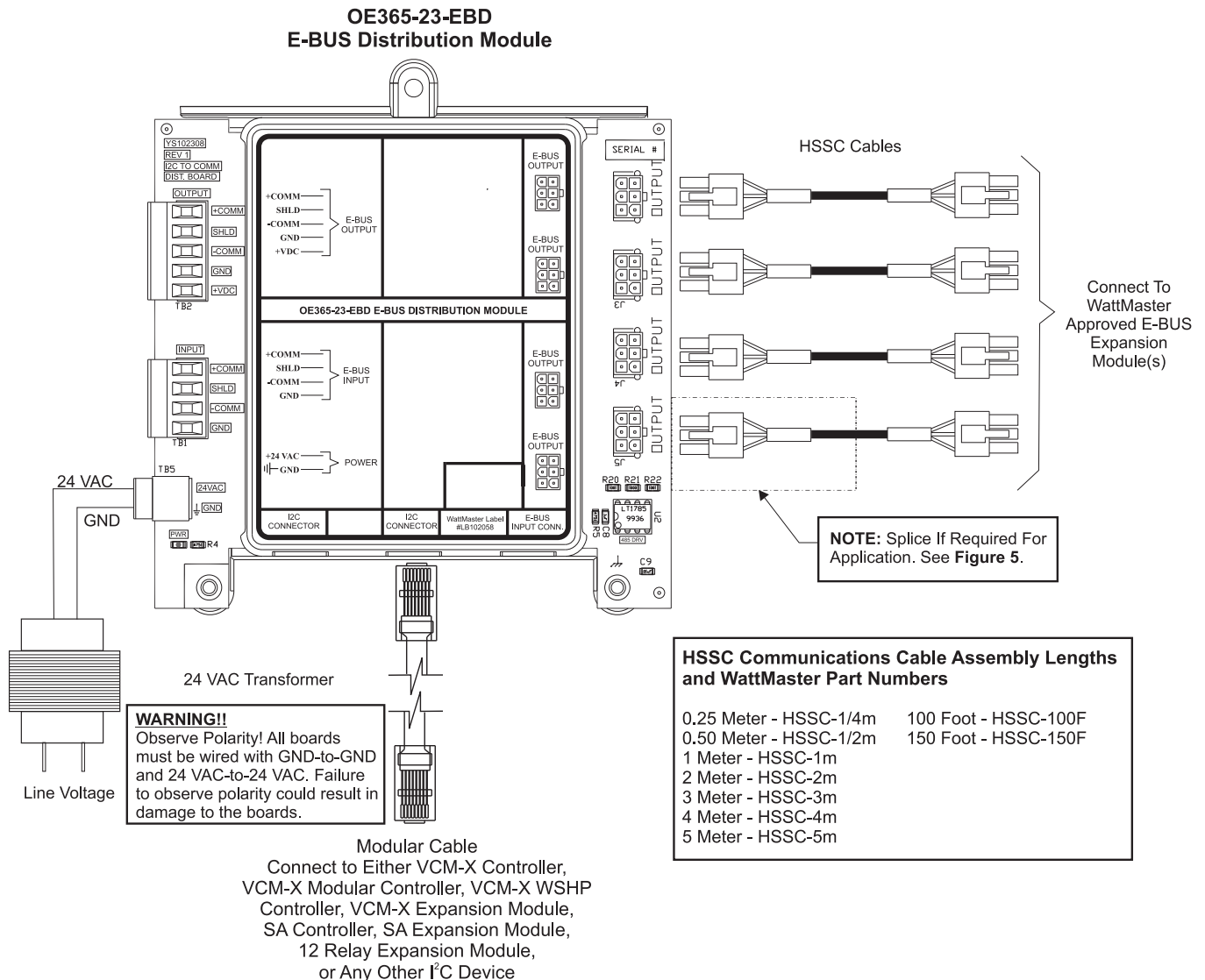

**Figure 3: E-BUS Distribution Module Wiring**

## Installation and Wiring

### E-BUS Modular Connection Wiring

Through its I<sup>2</sup>C port, the E-BUS Distribution Module can be connected to any of the following I<sup>2</sup>C controllers:

- VCM-X Controller (OE332-23-VCMX)
- VCM-X Modular Controller (OE332-23-VCMX-MOD)
- VCM-X WSHP Controller (OE332-23-VCMX-WSHP)
- VCM-X Expansion Module (OE333-23-EM)
- VCM-X 12 Relay Expansion Module (OE358-23-12R)
- SA Controller (OE332-SA-A)
- SA Expansion Module (OE333-23-SA-A)

The different E-BUS Modules listed on page 3 of this manual can be connected to the E-BUS Distribution Module using HSSC cables of various lengths (Figure 3). For modular connection wiring, see Figure 4. For applications requiring terminal block wiring to the E-BUS Distribution Module, see Figure 5.

All E-BUS Modules require a 24 VAC power connection with an appropriate VA rating.

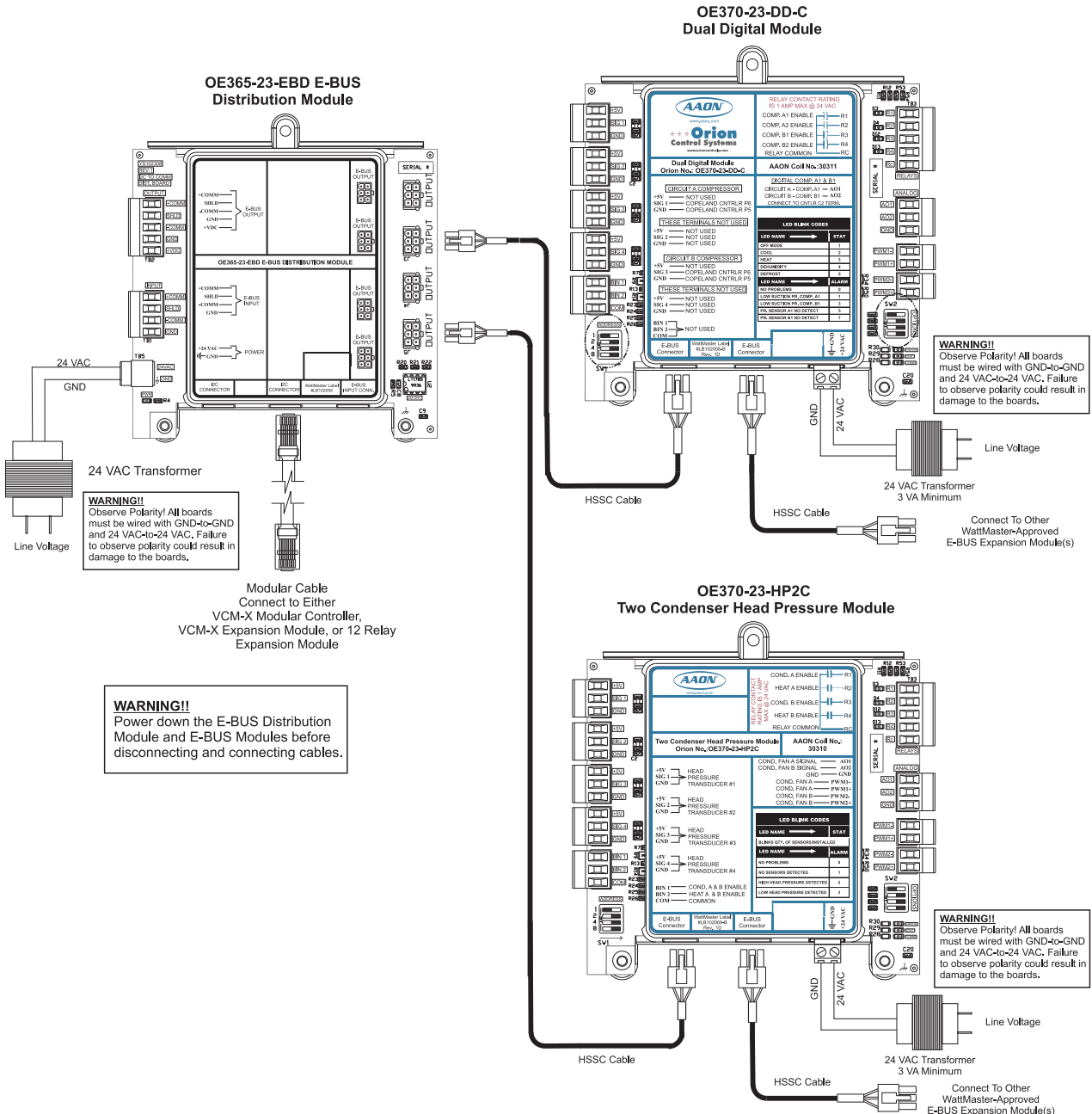

Figure 4: E-BUS Distribution Module Wiring

### E-BUS Terminal Blocks TB1 and TB2 Wiring

The E-BUS Terminal Blocks TB1 and TB2 provide an alternate method of connecting the E-BUS Distribution Module to the other modules. This method is used when it is necessary to pull the wire through conduit or to extend the length.

**WARNING:** Power down the E-BUS Distribution Module and E-BUS Module(s) before splicing the HSSC cable.

After removing the connector from the E-BUS Distribution end of the HSSC cable, wire or splice to the terminal blocks as follows:

**NOTE:** When extending the HSSC cable, do not exceed 200 feet without factory approval.

+ COMM	Black wire	RS-485 (+) communications
SHLD	Green wire	Shield or common internally tied to GND
- COMM	White wire	RS-485 (-) communications
GND	Not used	
+ VDC	Not used	Unregulated +DC voltage for powering certain sensors

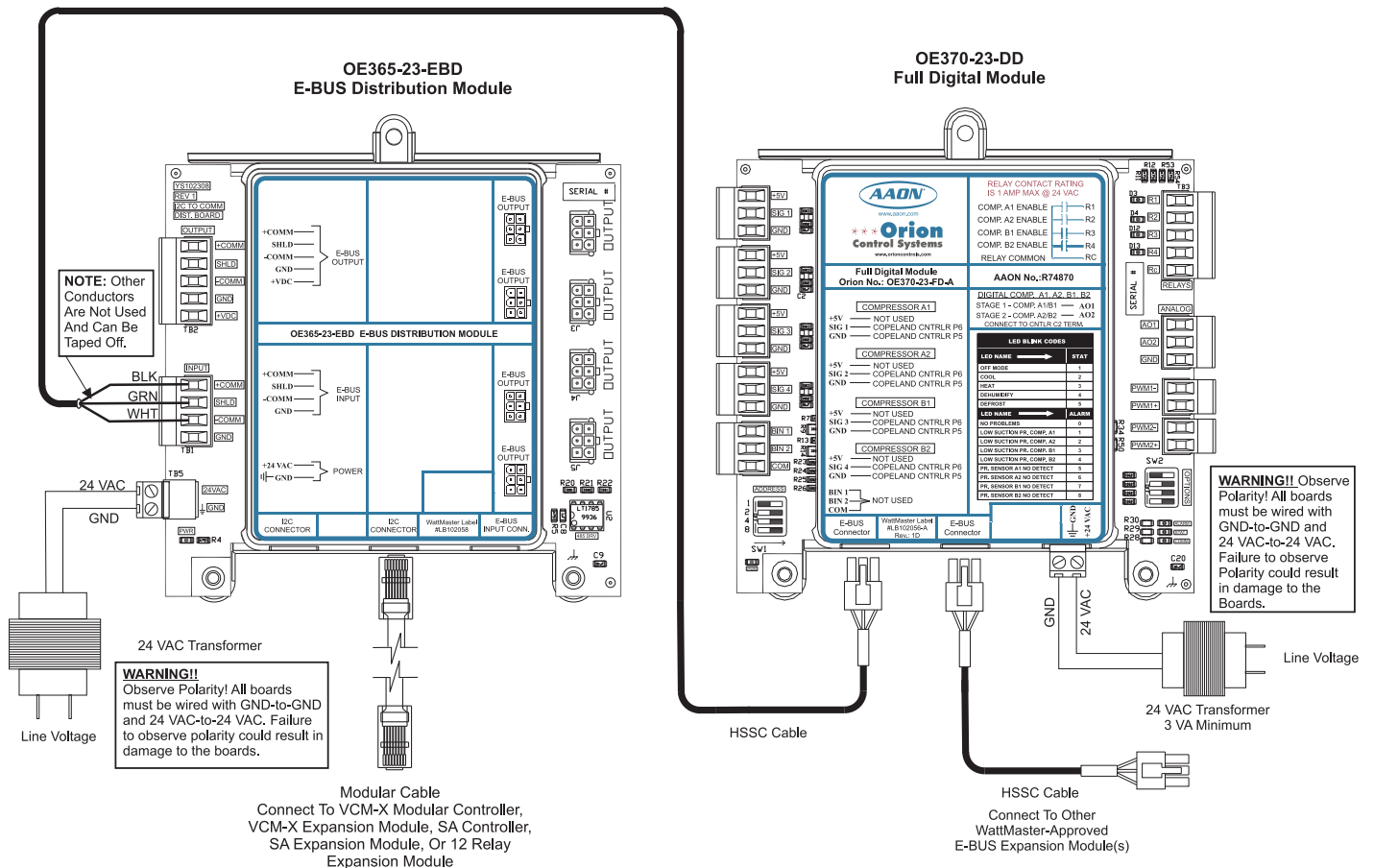

**Figure 5: E-BUS Distribution Terminal Block Wiring**

## Installation and Wiring

### EBTRON® Air Flow Measurement Digital Transmitter

**NOTE:** Only the EBTRON® GTN116 series of Modbus transmitters are compatible with the E-BUS Distribution Module and VCM-X Controller. No other series of EBTRON® transmitters will work for this application.

The E-BUS Distribution Module (OE365-23-EBD) can also be used for connecting the EBTRON® Airflow Measurement Digital Transmitter to the VCM-X Control System. You must wire the EBTRON® Airflow Measurement Digital Transmitters as shown in **Figure 6**.

The E-BUS Distribution Module provides a communications interface into the VCM-X Control System to enable the VCM-X Controller to monitor and display the airflow readings provided by the EBTRON® Transmitter.

**NOTE:** This option is not available for the SA Controller.

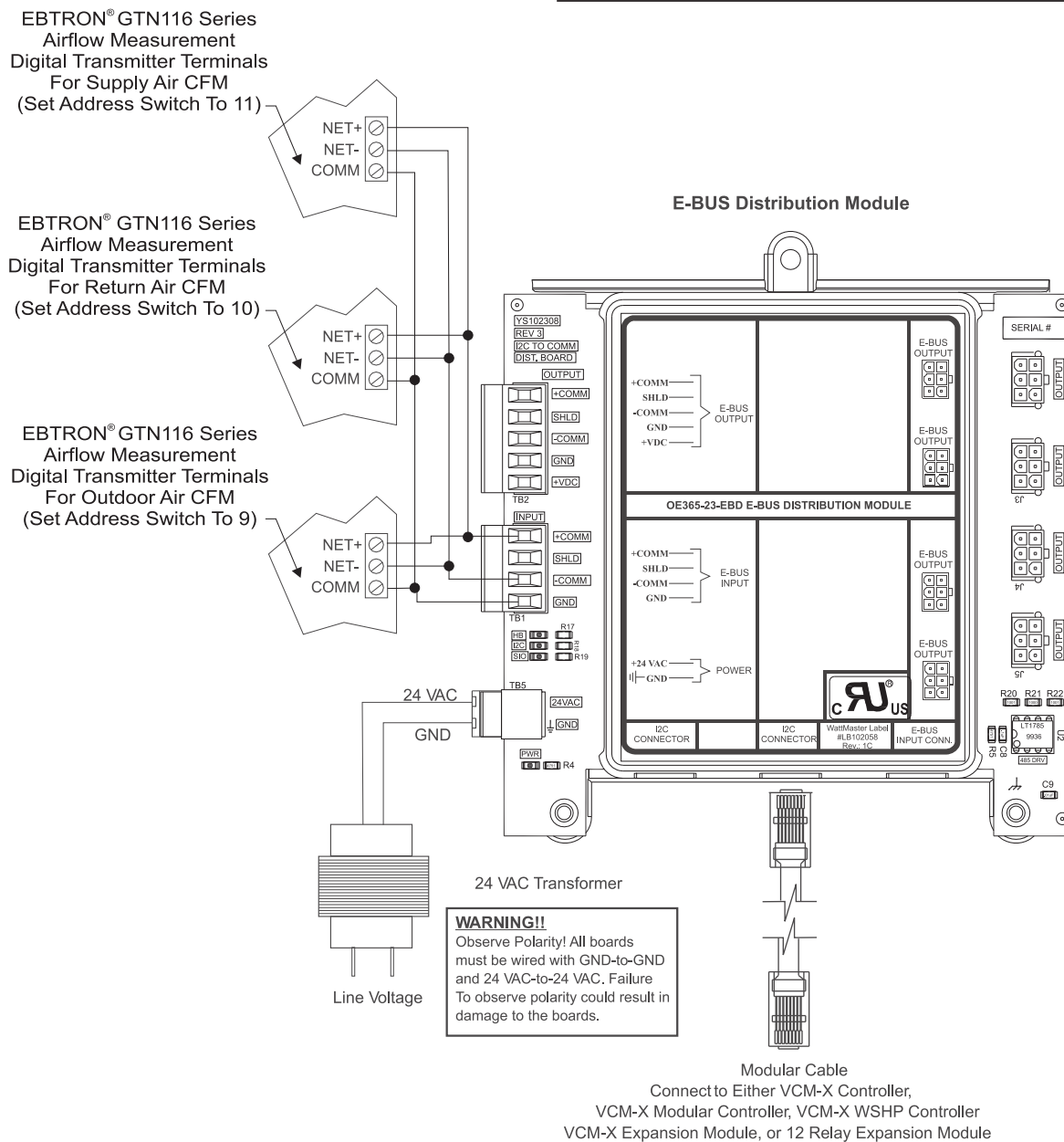

**Figure 6: EBTRON® GTN116 Series Digital Transmitter To E-BUS Wiring**

## Using LEDs to Verify Operation

The E-BUS Distribution Module is equipped with LEDs that can be used to verify operation and perform troubleshooting. The module has four LEDs—one used for power and the others for communication. See **Figure 7** for the LED locations. The LEDs associated with these inputs and outputs allow you to see what is active without using a voltmeter. The LEDs and their uses are as follows:

### Status LEDs

**“PWR”** - This LED will light up to indicate that 24 VAC power has been applied to the controller.

**“HB”** - If the board is programmed and the program is running, this LED will blink rapidly like a heartbeat. If the LED is not blinking, the board is either not powered up or is dead.

### Communication LEDs

**“I2C”** - When the VCM-X Controller, VCM-X Modular Controller, VCM-X WSHP Controller, VCM-X Expansion Module, SA Controller, SA Expansion Module, or 12 Relay Expansion Module sends a request for information via the I<sup>2</sup>C Port, this LED will blink on stating that the board received the request. If this LED is not blinking from time to time, Check the I<sup>2</sup>C cable connections.

**“SIO”** - After the E-BUS Distribution Module receives a valid request for information, it will send it out on the E-BUS side. At this time, this LED will blink. If this LED is not blinking, check the connections on the E-BUS side.

---

NOTE: In normal operation, the I<sup>2</sup>C and SIO LEDs should be alternating back and forth.

---

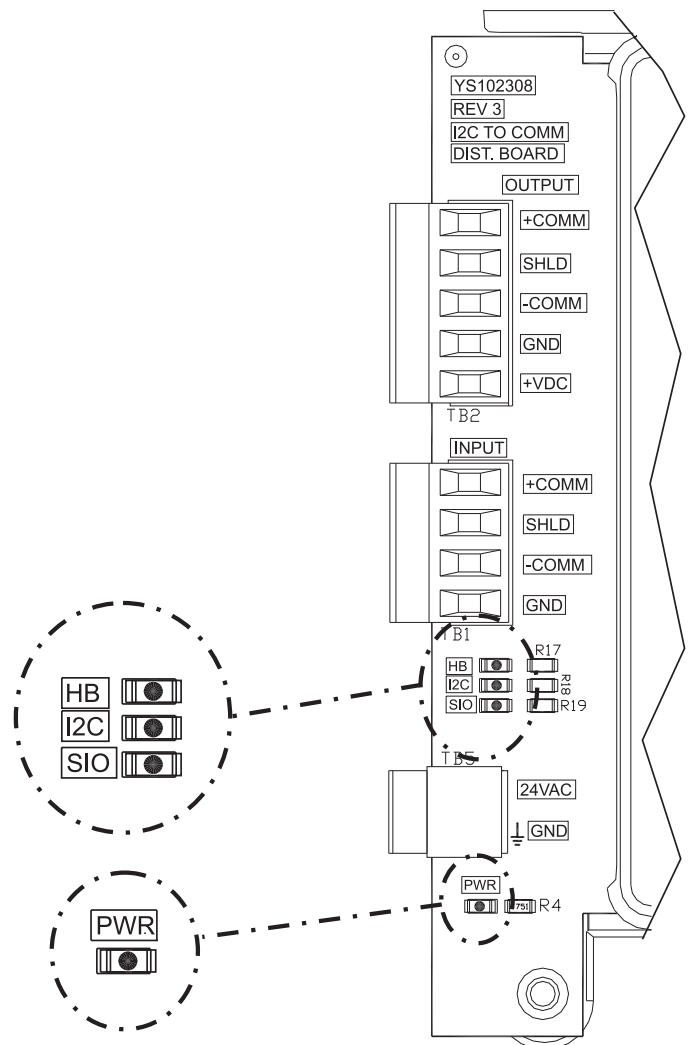

**Figure 7: LED Locations**

## Troubleshooting

---

### LED Diagnostics

---

**“POWER” LED:** When the E-BUS Distribution Module is powered up, the POWER LED should light up and stay on continuously. If it does not light up, check to be sure that the power wiring is connected to the module and that the connections are tight. If after making all these checks, the POWER LED does not light up, the module is most likely defective.

**“HB” LED:** When the E-BUS Distribution Module is powered up and running, this LED should blink rapidly like a heartbeat. If it fails to do so, the module is either not powered up or is dead.

**“I2C” LED:** If this LED is not blinking from time to time when the E-BUS Distribution Module is connected to one of the VCM-X Controllers, the VCM-X Expansion Module, the SA Controller, the SA Expansion Module, or the 12-Relay Expansion Module, check the I<sup>2</sup>C cable connections.

**“SIO” LED:** After the E-BUS Distribution Module receives a valid request for information, it will send it out on the E-BUS side. At this time, this LED will blink. If this LED is not blinking, check the connections on the E-BUS side.

### Other Checks

---

---

---

**NOTE:** The E-BUS Distribution Module contains no user-serviceable parts. Contact qualified technical personnel if your module is not operating correctly.

---

---





Form: OR-EBD-TGD-01G  
All rights reserved.

Printed in the USA

September 2010  
Copyright 2010

WattMaster Controls Inc. • 8500 NW River Park Drive • Parkville, MO • 64152  
Phone: 866-918-1100 • [www.orioncontrols.com](http://www.orioncontrols.com) • Fax (816) 505-1101

---