

Description

The OE331-21-AVG General Broadcast Device Controller (GBD) provides a method of connecting up to a maximum of 6 Room Temperature Sensors so that they can then be averaged and globally broadcast by the GBD to one VCM controller on a local loop. This General Broadcast Device also includes the ability to read up to 6 Carbon Dioxide sensors and average or find the highest reading and then broadcast the reading to one VCM controller on a local loop. It also provides a 0-10 VDC proportional reset voltage on Analog #1 on the GBD. The GBD calculates and varies the signal depending on the level of CO₂ in the space as it rises from an adjustable minimum setting to an adjustable maximum level. Also, if desired, Analog Output #2 can provide a 10.0 VDC fixed signal whenever the CO₂ is above the minimum setpoint.

Up to a maximum of (2) GBD controllers can be tied together to provide from 7 to 12 Room Temperature Sensors or CO₂ Sensors inputs. Each GBD controller can be used for either temperature averaging or CO₂ averaging but not both on the same GBD controller. When both are required at least 2 GBD controllers, one configured for CO₂ control and the other configured for Temperature averaging must be used.

Mounting

The GBD Controller is provided with an integral backplate for mounting inside of a control enclosure. It is recommended that the GBD Controller be mounted in the HVAC unit control enclosure, or in a control enclosure in the building equipment room. An optional factory control enclosure for the GBD Controller is available.

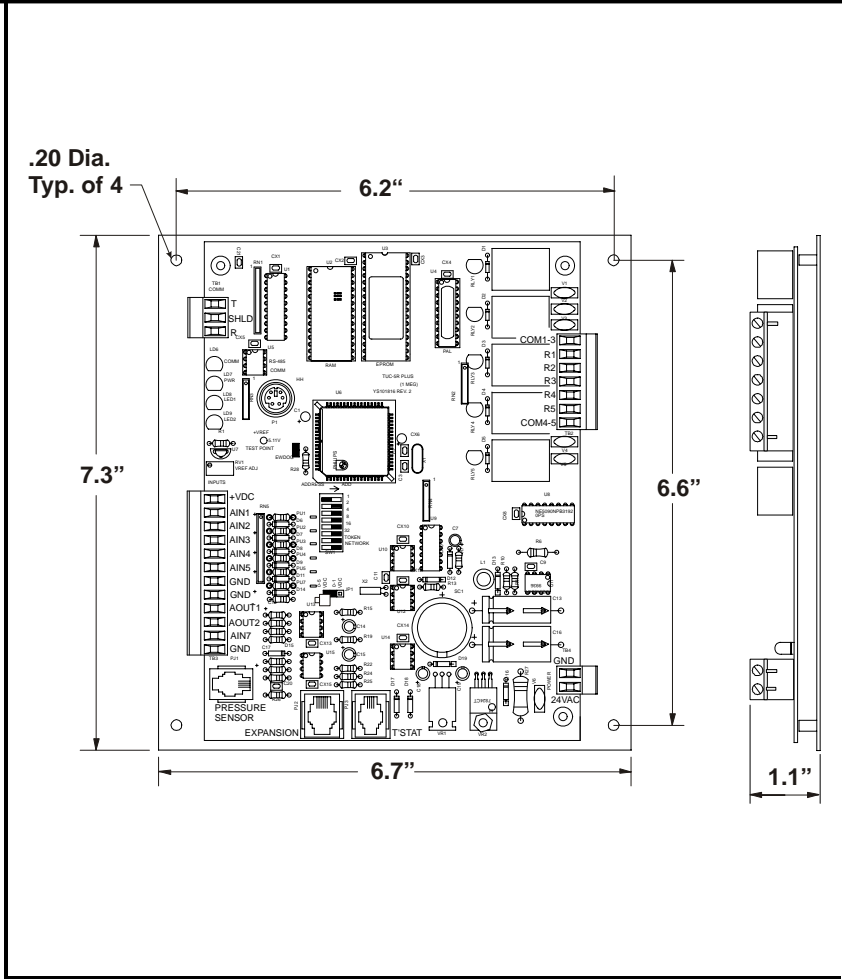

Technical Data		OE331-21-GPCPLUS GPC Plus Controller	
Power	24 Volt AC	Weight	1.5 lb.
Power Consumption	8 VA Maximum	Network Connection	RS-485
Operating Temp	10°F to 149°F	Protocol	HSI Open Protocol Token Passing
Operating Humidity	90% RH Non-Condensing	Communications	RS-485 - 9600 Baud
Inputs Available		Outputs Available:	
Types and Quantity of Usable Inputs	Type III-10kohm sensors	Usable Analog Output Qty.	(2) Available
	4-20ma sensors	AOUT1 Output Signal	0-10 VDC Variable Signal
	(6) available	AOUT2 Output Signal	10 VDC Fixed Signal
Three Year Warranty		WattMaster reserves the right to change specifications without notice	

July 27, 2006

General Broadcast Device

SS1017

DESCRIPTION: This is a modification of the original Averaging Broadcast Controller which provided a method to connect up to a maximum of 12 sensors to be averaged and globally broadcast to one VAV/CAV controller on a local loop. This General Broadcast Device also includes the ability to read Carbon Dioxide sensors and find the highest reading to be broadcast to one VAV/CAV or VCM controller. It also provides a proportional reset voltage on Analog #1 based on the level of CO₂ as it rises from an adjustable minimum setting to an adjustable maximum level.

Analog Output #2 provides a 10.0 vdc signal whenever the CO₂ is above the minimum setpoint.

Relay #1 is activated whenever the CO₂ rises above the minimum setting and de-activates when it falls 5 PPM below the setpoint.

Relay #2 is activated whenever the CO₂ rises above the maximum setting and de-activates when it falls 5 PPM below the setpoint.

LIMITATIONS: Only 6 sensors allowed controller. Requires a second controller board for sensors 7 to 12. The global analog broadcast channels are user selectable.

Celsius temperatures are not supported.

Unless verified by Mario, the VAV/CAV capable of receiving the averaging broadcast was custom code Y200301 version 2.02 or higher and not the standard SS1003 program.

Only the VCM can read the CO₂ for IAQ operations.

Any VAV/CAV or VCM per loop can have broadcast devices sending it data since the global receive channel is fixed at Global Analog #13 for temperature (if no space sensor installed) and #14 for CO₂ (if no sensor is installed).

HARDWARE: TUC-5R+ 1 Meg with no expansion capabilities supported.

PRISM version 2.7.0 or higher is required to program and monitor the GBC controllers.

APPLICATIONS: 6 or fewer Space Sensors or Carbon Dioxide Sensors

One SS1017 controller w/4 Sensors Installed.

Set the GBD controller to SEND on channel 13 for temperature or channel 14 for CO₂.

7 to 12 Space Sensors or Carbon Dioxide Sensors

Two SS1017 controllers with the 12 sensors spread among them as desired.

Set the first GBD controller to SEND on channel 13

Set the first GBD controller to RECEIVE on channel 24

Set the second GBD controller to SEND on channel 24

There are currently 22 assigned global analog channels, but not all globals are active on every system installation since some apply to Heat Pumps and some to Auto-Zone, etc.

NOTE: You cannot mix temperature sensors with carbon dioxide sensors on the same controller!

Up to (6) CO₂ Sensors Can Be Used On The GBD. They Can Be Wired To AIN1, AIN2, AIN3, AIN4, AIN5 And AIN7 As Desired. Only 4-20mA CO₂ Sensor(s) May Be Used.

The Pullup Resistor For The Analog Input That Each CO₂ Sensor Is Connected To Must Be Removed For Proper Operation Of The GBD Device.

Warning:
24 VAC Must Be Connected So That All Ground Wires Remain Common. Failure To Do So Will Result In Damage To The Controllers.

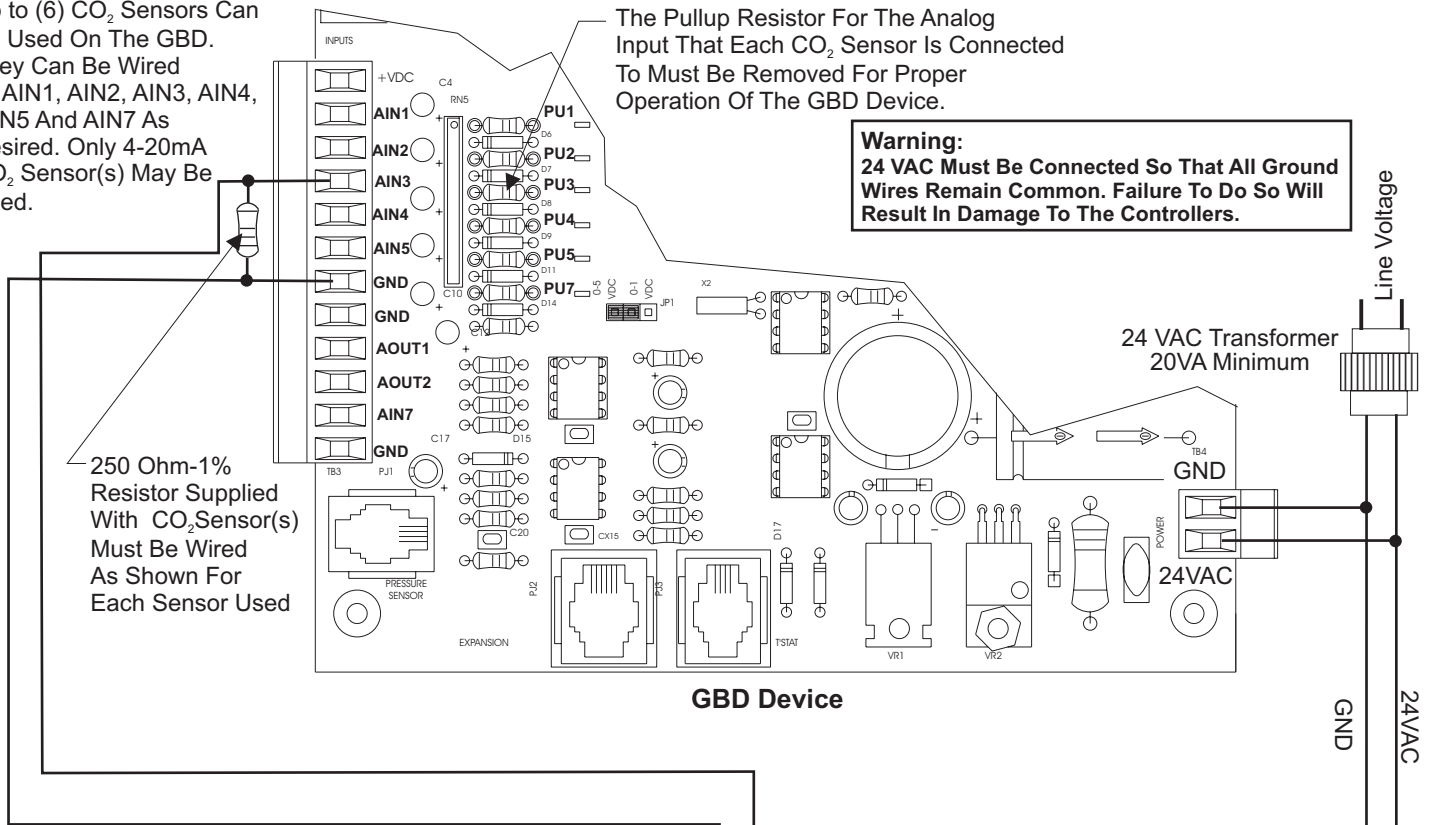

250 Ohm-1% Resistor Supplied With CO₂ Sensor(s) Must Be Wired As Shown For Each Sensor Used

Typical Wiring Shown For Input AIN3. Wiring For Other Inputs Is Identical.

**OE255 or OE256
CO₂ Sensor
(4-20mA Signal)**

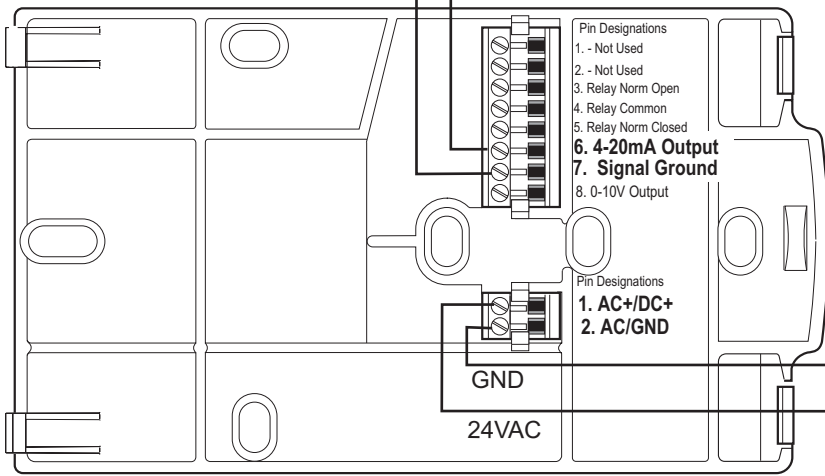

- Pin Designations
- 1. - Not Used
 - 2. - Not Used
 - 3. Relay Norm Open
 - 4. Relay Common
 - 5. Relay Norm Closed
 - 6. 4-20mA Output**
 - 7. Signal Ground**
 - 8. 0-10V Output

- Pin Designations
- 1. AC+/DC+**
 - 2. AC/GND**

**OE331-21-AVG
GBD Device Wiring
When Used For CO₂ Applications**

Notes:

- 1.) The GBD Can Either Be Used With CO₂ Sensors Or Space Temperature Sensors But Not Both On The Same GBD Device. Up to 2 GBD Devices Can Be Located On Each Local Loop.
- 2.) 24 VAC Must Be Connected So That All Ground Wires Remain Common.
- 3.) Set-up, Programming And Monitoring Of The GBD Device Requires The Use Of A Personal Computer And Prism Software.
- 4.) All Wiring To Be In Accordance With Local And National Electrical Codes And Specifications.

JOB NAME	
FILENAME	
OE331-21-AVG-GBD-Wire1A.CDR	
DATE: 10/07/05	DRAWN BY: B. CREWS
PAGE	DESCRIPTION:
2 of 5	OE331-21- AVG
GBD Device Wiring	

Connect The GBD To The Same Local Communications Loop As The Controller That Will Be Receiving the GBD Broadcast

GBD Device

Communications Wire Must Be 2 Conductor Twisted Pair With Shield, Belden #82760 Or Equivalent. All Wiring Must Be Straight Through, R To R, T To T And SHLD To SHLD.

Available Inputs For Connection of Space Temperature Sensors. See Page 4 For Detailed Space Temperature Sensor Wiring

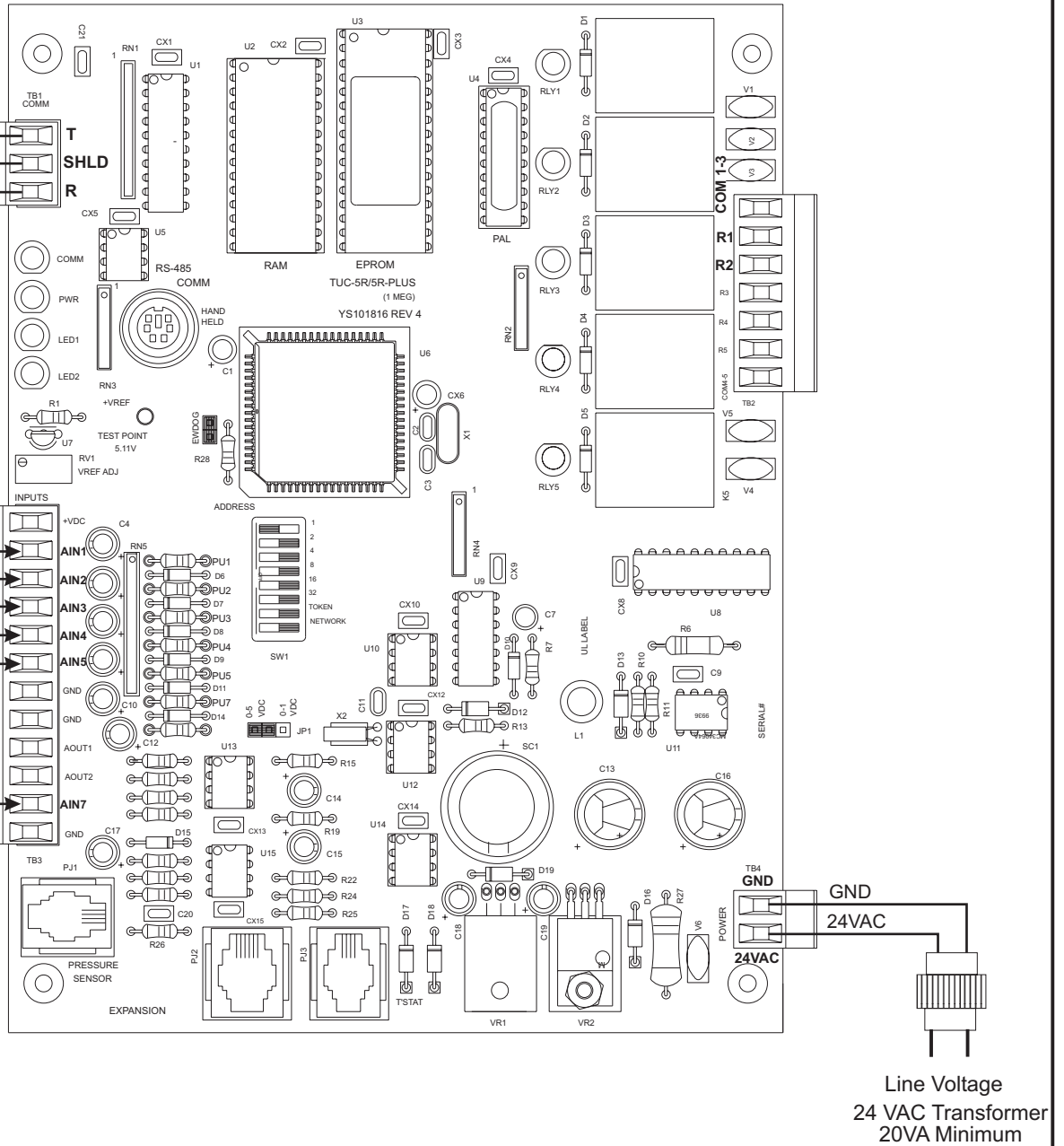

OE331-21-AVG GBD Device Wiring When Used For Space Temperature Sensor Averaging Applications

Notes:

- 1.) The GBD Can Either Be Used With CO2 Sensors Or Space Temperature Sensors But Not Both On The Same GBD Device. Up to 2 GBD Devices Can Be Located On Each Local Loop.
- 2.) 24 VAC Must Be Connected So That All Ground Wires Remain Common.
- 3.) Set-up, Programming And Monitoring Of The GBD Device Requires The Use Of A Personal Computer And Prism Software.
- 4.) All Wiring To Be In Accordance With Local And National Electrical Codes And Specifications.

JOB NAME	
FILENAME	
OE331-21-AVG-GBD-Wire1A.CDR	
DATE: 10/07/05	DRAWN BY: B. CREWS
PAGE	DESCRIPTION:
3 of 5	OE331-21- AVG GBD Device Wiring

Up to (6) Temperature Sensors Can Be Used On The GBD. They Can Be Wired To AIN1, AIN2, AIN3, AIN4, AIN5 And AIN7 As Desired.

Warning:
24 VAC Must Be Connected So That All Ground Wires Remain Common. Failure To Do So Will Result In Damage To The Controllers.

Typical Wiring Shown For Input AIN3. Wiring For Other Inputs Is Identical.

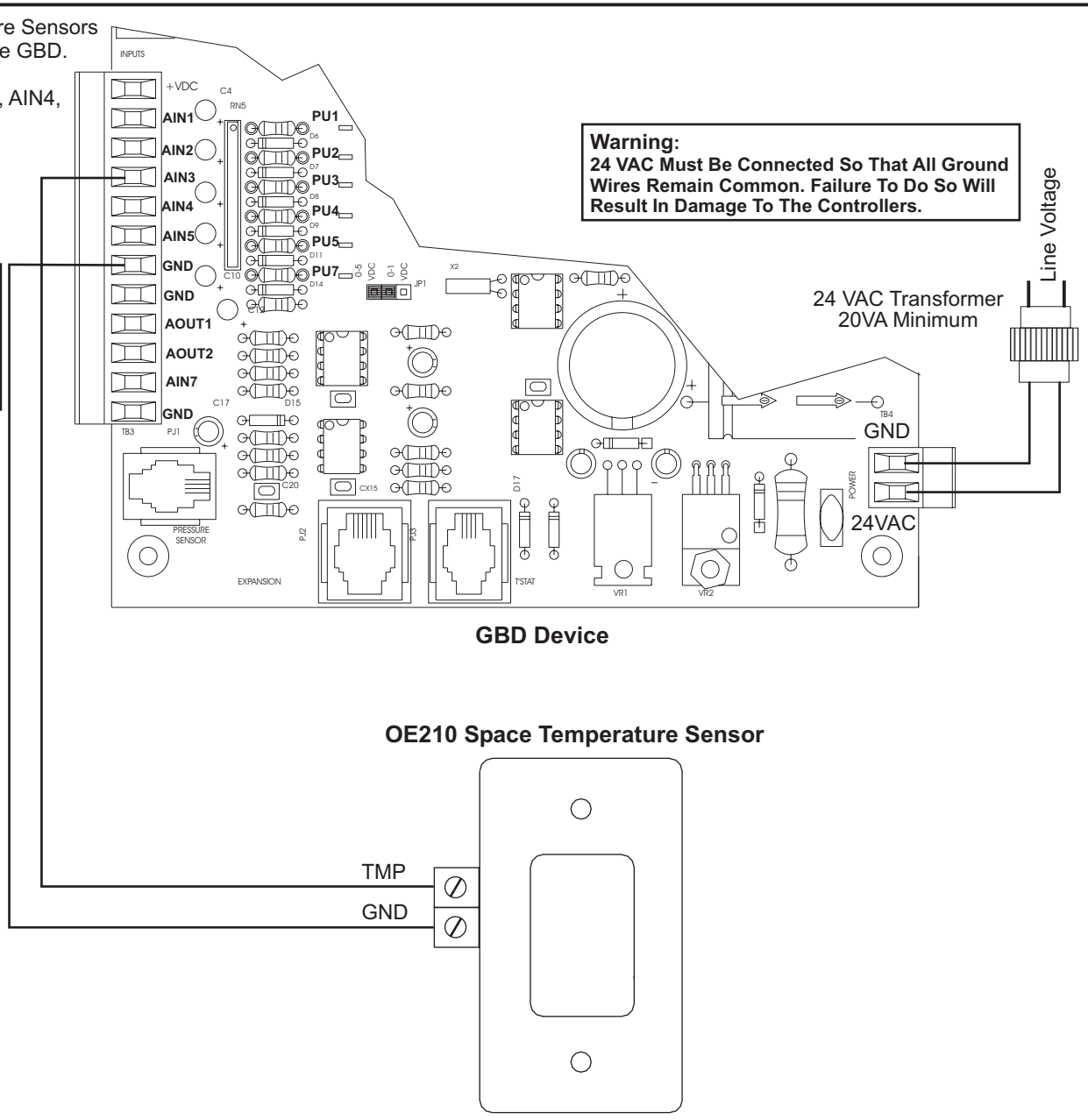

**OE331-21-AVG
GBD Device Wiring
When Used For Space Temperature Sensor Averaging Applications**

Notes:

- 1.) The GBD Can Either Be Used With CO2 Sensors Or Space Temperature Sensors But Not Both On The Same GBD Device. Up to 2 GBD Devices Can Be Located On Each Local Loop.
- 2.) 24 VAC Must Be Connected So That All Ground Wires Remain Common.
- 3.) Set-up, Programming And Monitoring Of The GBD Device Requires The Use Of A Personal Computer And Prism Software.
- 4.) All Wiring To Be In Accordance With Local And National Electrical Codes And Specifications.

JOB NAME	
FILENAME	
OE331-21-AVG-GBD-Wire1A.CDR	
DATE: 10/07/05	DRAWN BY: B. CREWS
PAGE	DESCRIPTION:
4 of 5	OE331-21- AVG
	GBD Device Wiring

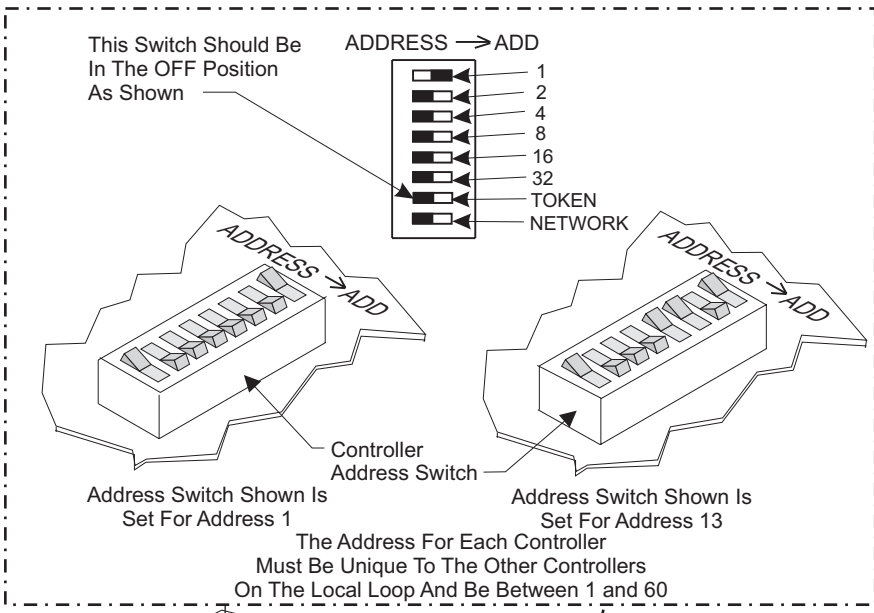

Note:
The Power To The Controller Must Be Removed And Reconnected After Changing The Address Switch Settings In Order For Any Changes To Take Effect.

Caution
Disconnect All Communication Loop Wiring From The Controller Before Removing Power From The Controller. Reconnect Power And Then Reconnect Communication Loop Wiring.

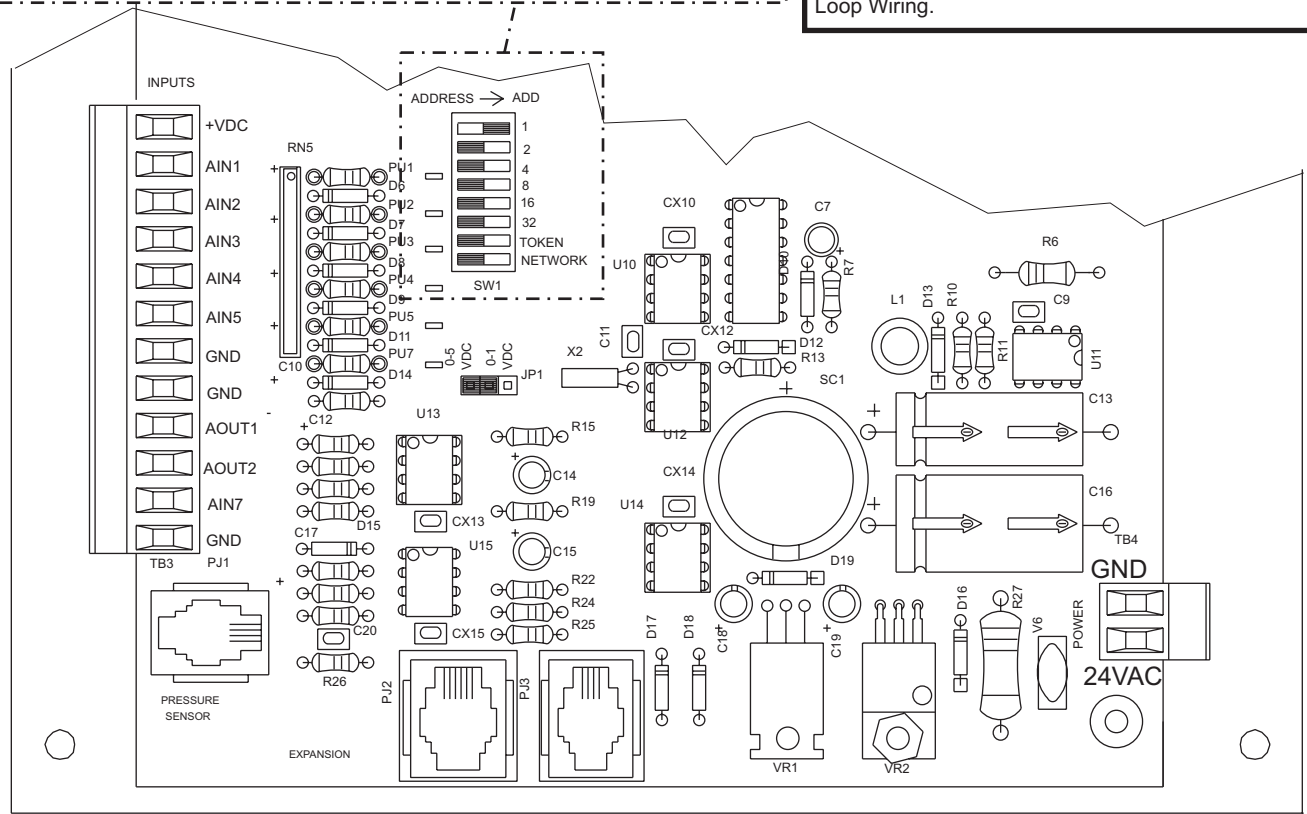

Notes:

- 1.) The GBD Can Either Be Used With CO2 Sensors Or Space Temperature Sensors But Not Both On The Same GBD Device. Up to 2 GBD Devices Can Be Located On Each Local Loop.
- 2.) 24 VAC Must Be Connected So That All Ground Wires Remain Common.
- 3.) Set-up, Programming And Monitoring Of The GBD Device Requires The Use Of A Personal Computer And Prism Software.
- 4.) All Wiring To Be In Accordance With Local And National Electrical Codes And Specifications.

JOB NAME	
FILENAME	
OE331-21-AVG-GBD-Wire1A.CDR	
DATE: 10/07/05	DRAWN BY: B. CREWS
PAGE	DESCRIPTION:
5 of 5	OE331-21- AVG GBD Device Wiring